

NOTES

1. MATERIAL: AL AL 6061 T6
2. REMOVE BURRS AND SHARP EDGES.
3. FILLET R0.3 MAX UNLESS OTHERWISE SPECIFIED.
4. FINISH: ANODIC COATING DYED BLACK 12 MICRON.

REVISIONS				
ZONE	REV.	DESCRIPTION	DATE	APPROVED
	A		10/25/2015	

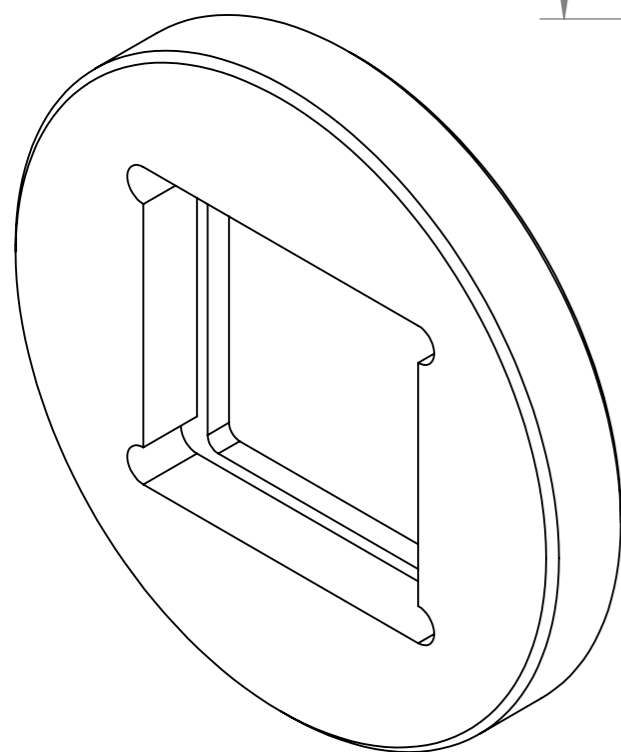
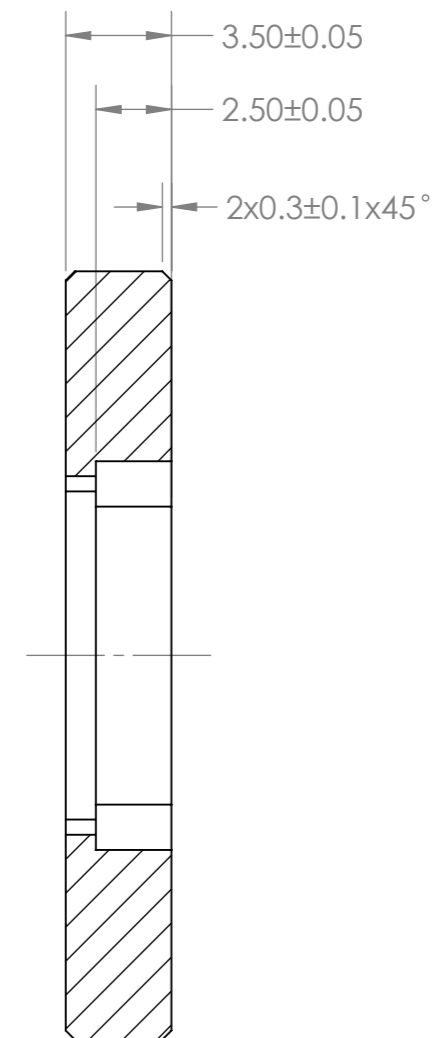
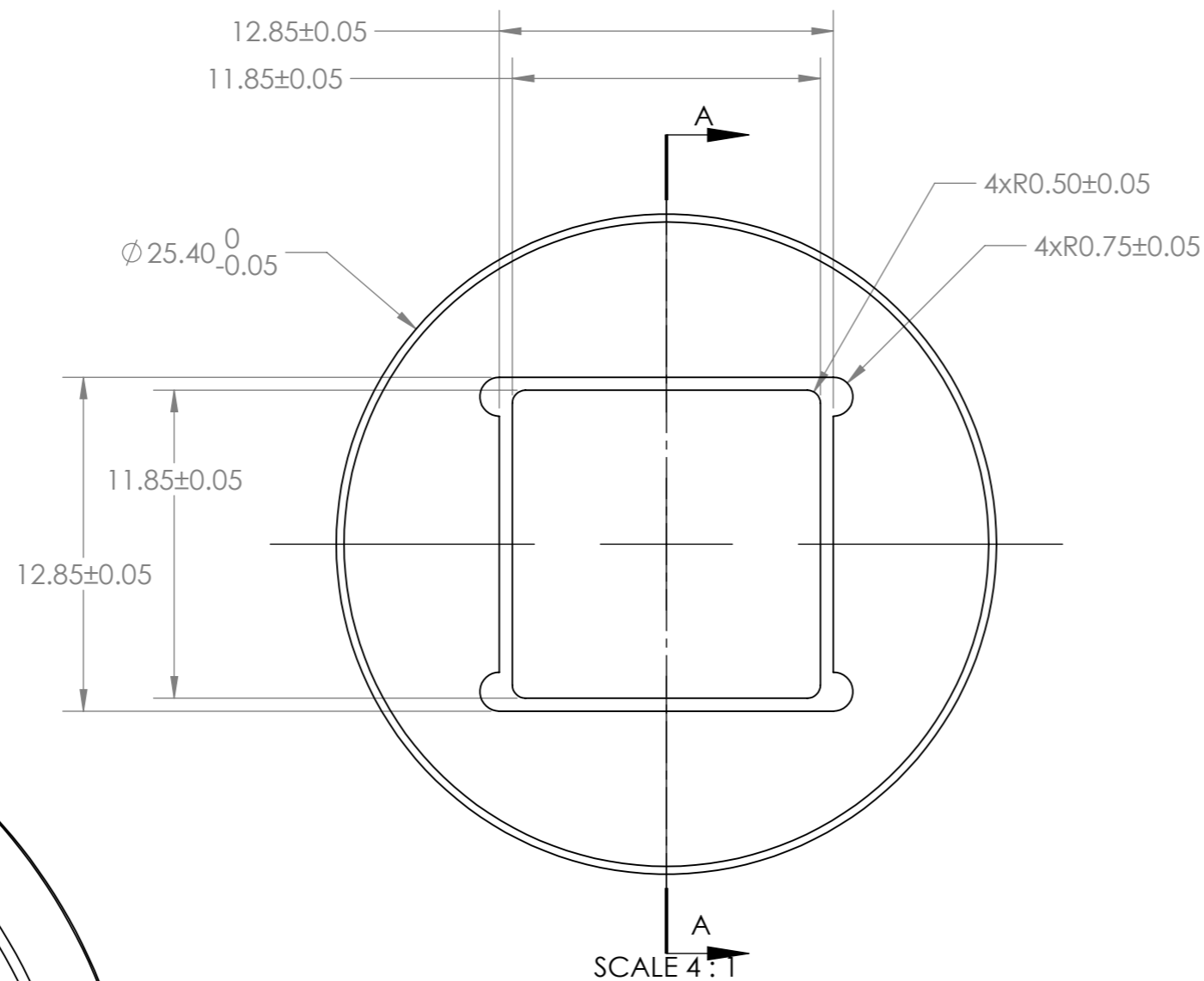

UNLESS OTHERWISE SPECIFIED: DIMENSIONS ARE IN MILLIMETERS SURFACE FINISH: TOLERANCES: LINEAR: ±0.1 ANGULAR: ±0.5°		FINISH:	DEBUR AND BREAK SHARP EDGES	DO NOT SCALE DRAWING	REVISION A
DRAWN G.S.		SIGNATURE	DATE 6/12/15	THIS DRAWING IS THE PROPERTY OF HOLO/OR. DUPLICATION OR SUBMISSION TO THIRD PARTIES REQUIRES HOLO/OR'S WRITTEN CONSENT.	
CHK'D L.S.			DATE 6/12/15	TITLE: Adapter for square 12.7x12.7mm to 1" dia	
APPV'D				DWG/PART NO. AD SQ07 T01	
MFG				A3	
Q.A				MATERIAL:	
				WEIGHT:	
				SCALE:10:1	
				SHEET 1 OF 1	

