

NOTES

1. MATERIAL: AL AL 6061 T6
2. REMOVE BURRS AND SHARP EDGES.
3. FILLET R0.3 MAX UNLESS OTHERWISE SPECIFIED.
4. FINISH: ANODIC COATING DYED BLACK 12 MICRON.

REVISIONS				
ZONE	REV.	DESCRIPTION	DATE	APPROVED
	A		10/25/2015	

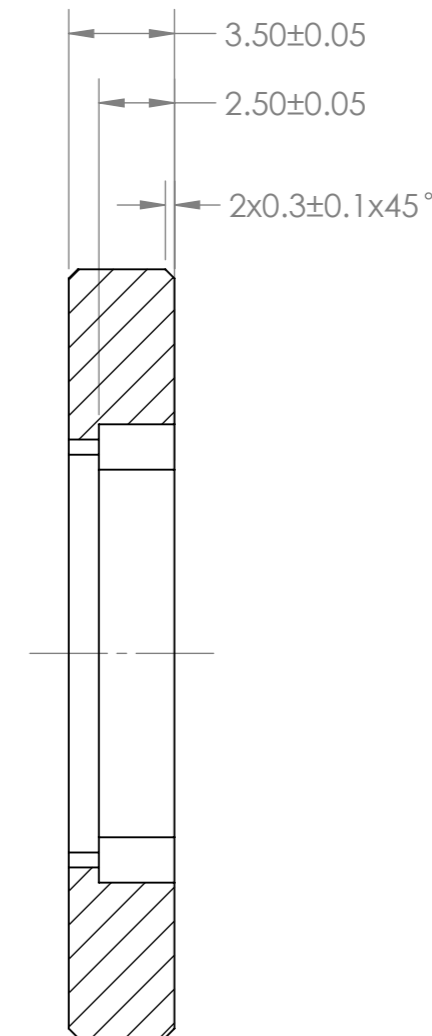
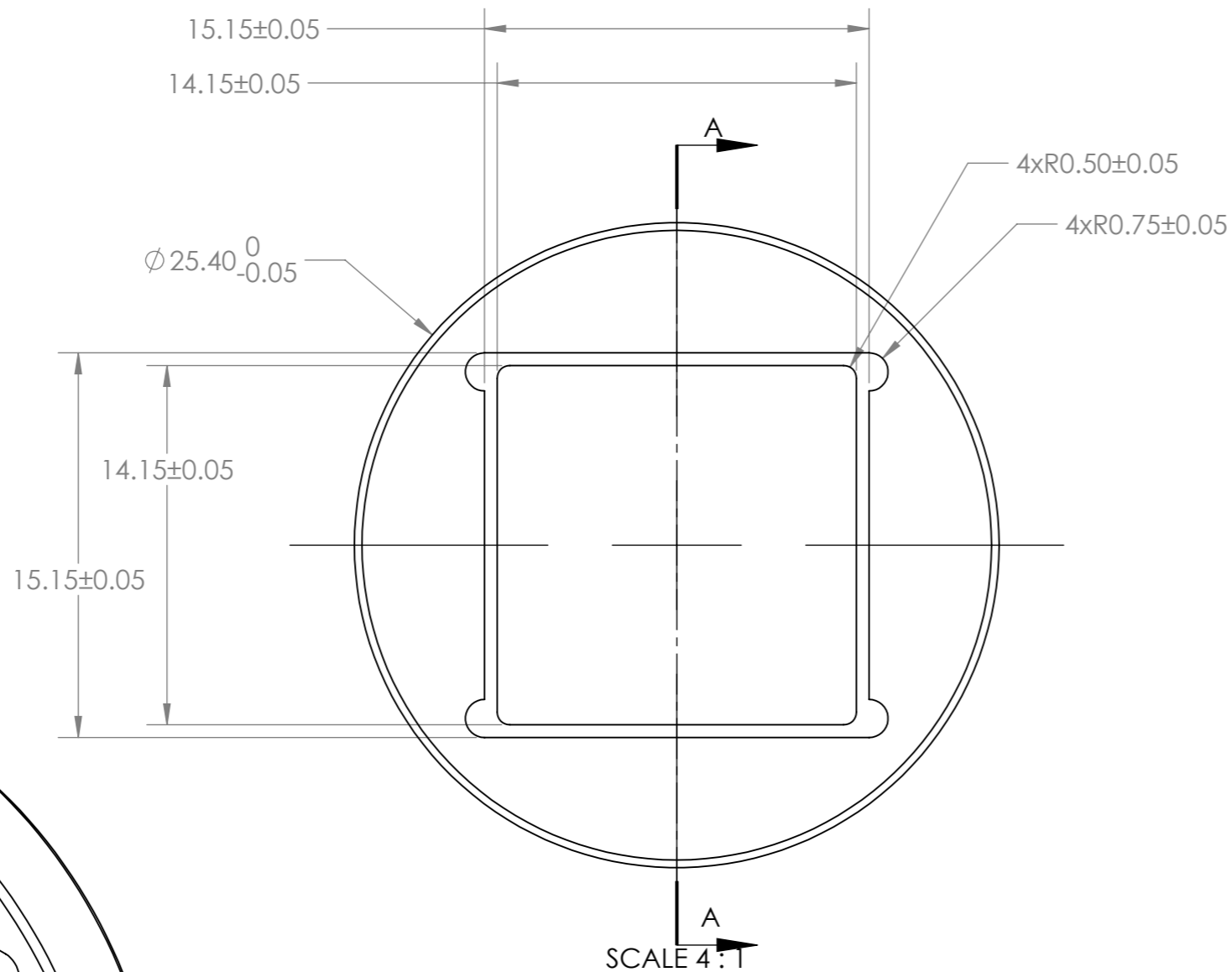

SECTION A-A
SCALE 4 : 1

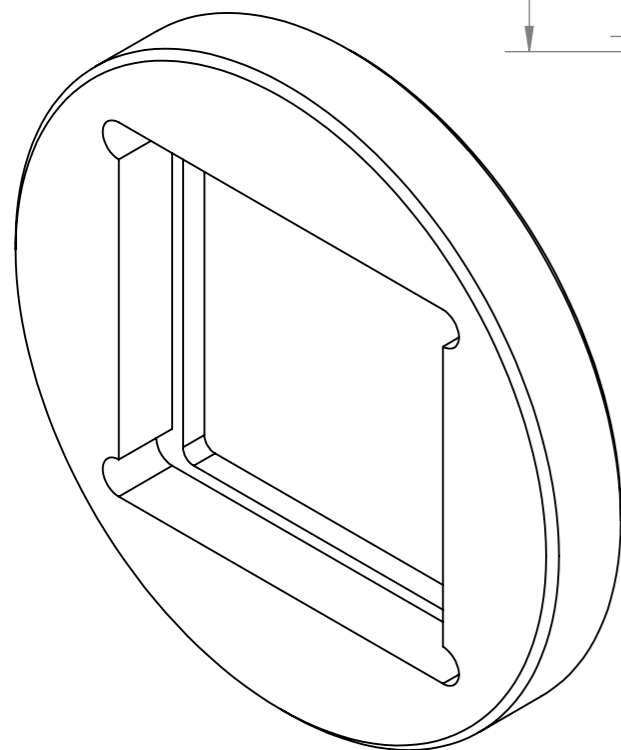

SCALE 4 : 1

SCALE 4 : 1

UNLESS OTHERWISE SPECIFIED: DIMENSIONS ARE IN MILLIMETERS SURFACE FINISH: TOLERANCES: LINEAR: ±0.1 ANGULAR: ±0.5°		FINISH:	DEBUR AND BREAK SHARP EDGES	DO NOT SCALE DRAWING	REVISION	A																		
<table border="1"> <thead> <tr> <th>NAME</th> <th>SIGNATURE</th> <th>DATE</th> </tr> </thead> <tbody> <tr> <td>DRAWN G.S.</td> <td></td> <td>6/12/15</td> </tr> <tr> <td>CHK'D L.S.</td> <td></td> <td>6/12/15</td> </tr> <tr> <td>APPV'D</td> <td></td> <td></td> </tr> <tr> <td>MFG</td> <td></td> <td></td> </tr> <tr> <td>Q.A</td> <td></td> <td></td> </tr> </tbody> </table>				NAME	SIGNATURE	DATE	DRAWN G.S.		6/12/15	CHK'D L.S.		6/12/15	APPV'D			MFG			Q.A			<p>THIS DRAWING IS THE PROPERTY OF HOLO/OR. DUPLICATION OR SUBMISSION TO THIRD PARTIES REQUIRES HOLO/OR'S WRITTEN CONSENT.</p>		
NAME	SIGNATURE	DATE																						
DRAWN G.S.		6/12/15																						
CHK'D L.S.		6/12/15																						
APPV'D																								
MFG																								
Q.A																								
				<p>TITLE: Adapter for square 15x15mm to 1" dia</p>																				
MATERIAL:				DWG/PART NO.		A3																		
WEIGHT:				SCALE:10:1		SHEET 1 OF 1																		
				AD SQ06 T01																				